

Thursday 18 May 2017 – Morning

**GCSE TWENTY FIRST CENTURY SCIENCE
CHEMISTRY A/SCIENCE A**

A171/01 Modules C1 C2 C3 (Foundation Tier)

Candidates answer on the Question Paper.
A calculator may be used for this paper.

OCR supplied materials:

None

Other materials required:

- Pencil
- Ruler (cm/mm)

Duration: 1 hour



| | | | |
|-----------------------|--|----------------------|--|
| Candidate forename | | Candidate surname | |
|-----------------------|--|----------------------|--|

| | | | | | | | | | | |
|---------------|--|--|--|--|--|------------------|--|--|--|--|
| Centre number | | | | | | Candidate number | | | | |
|---------------|--|--|--|--|--|------------------|--|--|--|--|

INSTRUCTIONS TO CANDIDATES

- Write your name, centre number and candidate number in the boxes above. Please write clearly and in capital letters.
- Use black ink. HB pencil may be used for graphs and diagrams only.
- Answer **all** the questions.
- Read each question carefully. Make sure you know what you have to do before starting your answer.
- Write your answer to each question in the space provided. Additional paper may be used if necessary but you must clearly show your candidate number, centre number and question number(s).
- Do **not** write in the barcodes.

INFORMATION FOR CANDIDATES

- The quality of written communication is assessed in questions marked with a pencil (✎).
- The Periodic Table is printed on the back page.
- The number of marks is given in brackets [] at the end of each question or part question.
- The total number of marks for this paper is **60**.
- This document consists of **20** pages. Any blank pages are indicated.

PLEASE DO NOT WRITE ON THIS PAGE

- 1 The exhaust gases of cars contain pollutants.
One of the pollutants is nitrogen monoxide.

(a) Put a **ring** around the correct words in each line to describe how nitrogen monoxide is formed in cars.

Nitrogen monoxide forms when nitrogen from the **air / petrol**
combines with **oxygen / carbon dioxide / water** from the air
at a **high / low** temperature inside the engine.

[2]

(b) Cars are fitted with catalytic converters.

A reaction in the catalytic converter converts the nitrogen monoxide into a harmless gas.

This is the equation for the reaction.

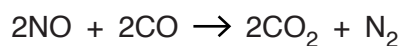

Which statement about the reaction is **true**?

Put a tick (✓) in the box next to the correct answer.

Nitrogen monoxide is oxidised to form nitrogen dioxide.

Nitrogen monoxide is reduced to form nitrogen dioxide.

Nitrogen monoxide is oxidised to form nitrogen.

Nitrogen monoxide is reduced to form nitrogen.

[1]

- (c) A town council wanted to reduce the amount of air pollutants in a town. The council decided to introduce a payment zone for cars.

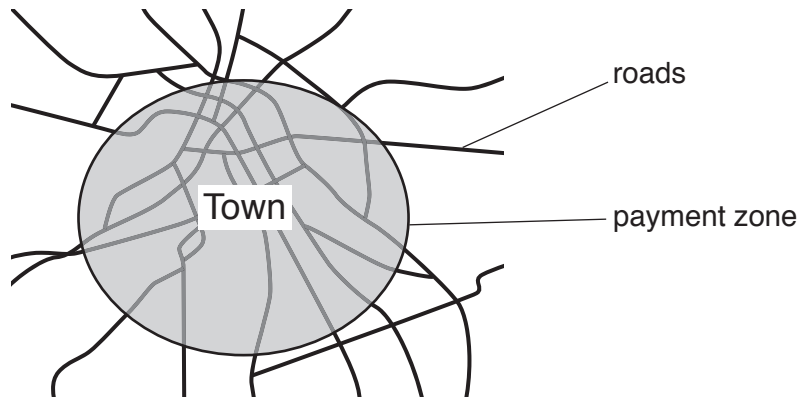

- (i) Why did the council think that a payment for cars to enter the town would improve air quality in the town?

.....

.....

..... [2]

(ii) Alex works for the town council.

Alex measured the amount of pollutants in the air inside the payment zone and outside the payment zone.

He recorded data every day for a year before the payment was introduced and every day for a year afterwards.

The table shows Alex's data.

| Site | Pollutant | Daily mean amount before the payment was introduced in $\mu\text{g}/\text{m}^3$ | Daily mean amount after the payment was introduced in $\mu\text{g}/\text{m}^3$ | Percentage change in % |
|--------------------------|-----------------|---|--|------------------------|
| Outside the payment zone | nitrogen oxides | 560 | 476 | -15 |
| | carbon monoxide | 25 | 22 | -12 |
| Inside the payment zone | nitrogen oxides | 600 | 480 | -20 |
| | carbon monoxide | 30 | 24 | -20 |

Suzy and Martin talk about the data in the table.

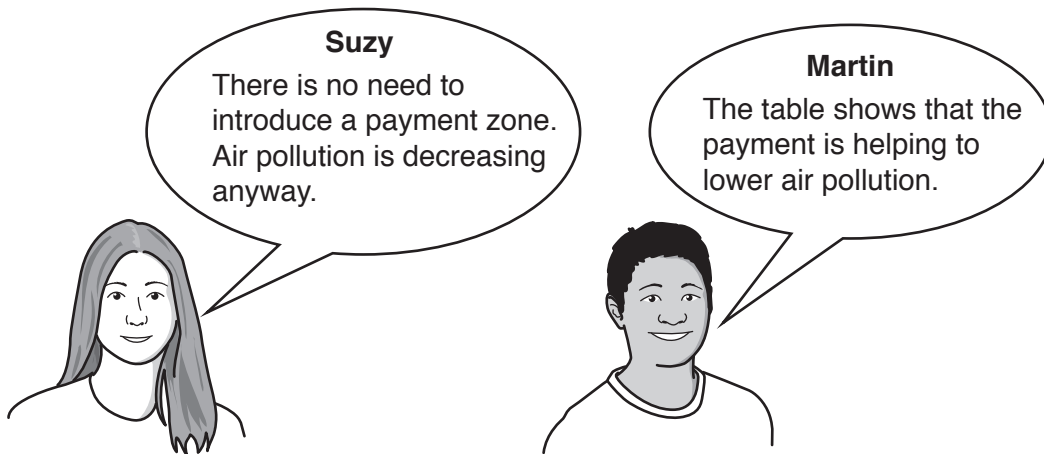

Explain how the data in the table supports the ideas of both Suzy and Martin.

.....

.....

.....

..... [3]

[Total: 8]

2 Sulfur dioxide is an air pollutant which is formed when fossil fuels are burned in power stations and in motor vehicles.

(a) How does the sulfur dioxide form?

Put a tick (✓) in the box next to the correct answer.

Sulfur in the fuel burns.

Sulfur reacts with nitrogen in the air.

Sulfur dioxide is added to fossil fuels to help them burn.

Incomplete combustion of carbon compounds in the fuel.

[1]

(b) Sulfur dioxide is damaging to the environment because it causes acid rain.

Complete the following sentence which describes how acid rain is formed.
Choose from the following words.

chlorine

nitrogen

oxygen

sulfur

water

Acid rain is formed when sulfur dioxide reacts with

and

[2]

3 The amounts of gases in the Earth's atmosphere have changed since the atmosphere first formed.

(a) Complete the following statements about the atmosphere and how it has changed. Choose from the following words.

argon carbon dioxide nitrogen oxygen water

(i) When the Earth's atmosphere first formed, it contained mainly water vapour and [1]

(ii) After plants appeared, photosynthesis produced more [1]

(iii) The Earth's atmosphere now contains approximately:

21% oxygen

78%

1% [2]

[Total: 4]

BLANK PAGE

PLEASE DO NOT WRITE ON THIS PAGE

4 Crude oil contains hydrocarbons.

The table shows information about some of the hydrocarbons in crude oil.

| Hydrocarbon | Number of carbons in one molecule | Properties | | | |
|-------------|-----------------------------------|---------------------|---------------------|----------------|------------------------------|
| | | Melting point in °C | Boiling point in °C | State at 25 °C | Density in g/cm ³ |
| Methane | 1 | -182 | -161 | gas | 0.42 |
| Ethane | 2 | -183 | -89 | | 0.55 |
| Propane | 3 | -188 | -42 | gas | 0.50 |
| Butane | 4 | -135 | 0 | gas | 0.58 |
| Pentane | 5 | -130 | 36 | liquid | 0.63 |
| Octane | 8 | -57 | 126 | liquid | 0.70 |
| Undecane | 11 | -26 | 196 | liquid | 0.74 |
| Dodecane | 12 | -10 | 216 | | 0.75 |
| Eicosane | 20 | 37 | 344 | solid | 0.79 |

- (a) Predict the states at room temperature for **ethane** and **dodecane**.
Write your answers in the table.

[2]

5 Nanoparticles are very small particles.

(a) Which statements about nanoparticles are **true** and which are **false**?

Put a tick (✓) in one box in each row.

| | True | False |
|--|------|-------|
| Nanoparticles can be used to make sports equipment stronger. | | |
| Nanoparticles can occur naturally. | | |
| Nanoparticles have the same properties as larger particles. | | |
| Nanoparticles are about the same size as molecules. | | |

[2]

(b) Doctors use stitches to hold together large cuts so that they can heal properly.

Doctor Khalique is considering buying a new type of material to use for stitches.

He needs to choose between a material that contains silver nanoparticles and a material that does not.

(i) Doctor Khalique thinks that there are advantages of using the material that contains nanoparticles instead of the material that does not.

Give **one** advantage of using the material with silver nanoparticles for stitches.

.....
 [1]

(ii) Doctor Khalique has some concerns about using a material that contains nanoparticles on patients.

Give **one** reason against using nanoparticles.

.....
 [1]

(iii) Doctor Khalique decides to buy the new material with nanoparticles.

Use the ideas of risk and benefit to justify his decision.

.....
 [1]

[Total: 5]

6 Chris works for a company that makes golf clubs.

The flexibility of the shaft of the golf club is important.

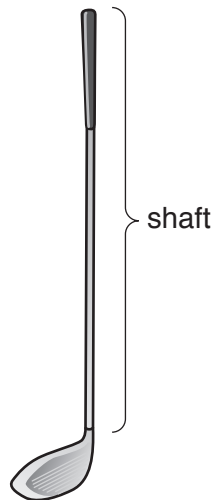

Golf clubs are given a Flex Rating as a measure of the flexibility of the shaft.

Chris measures the flexibility of a shaft using the following apparatus.

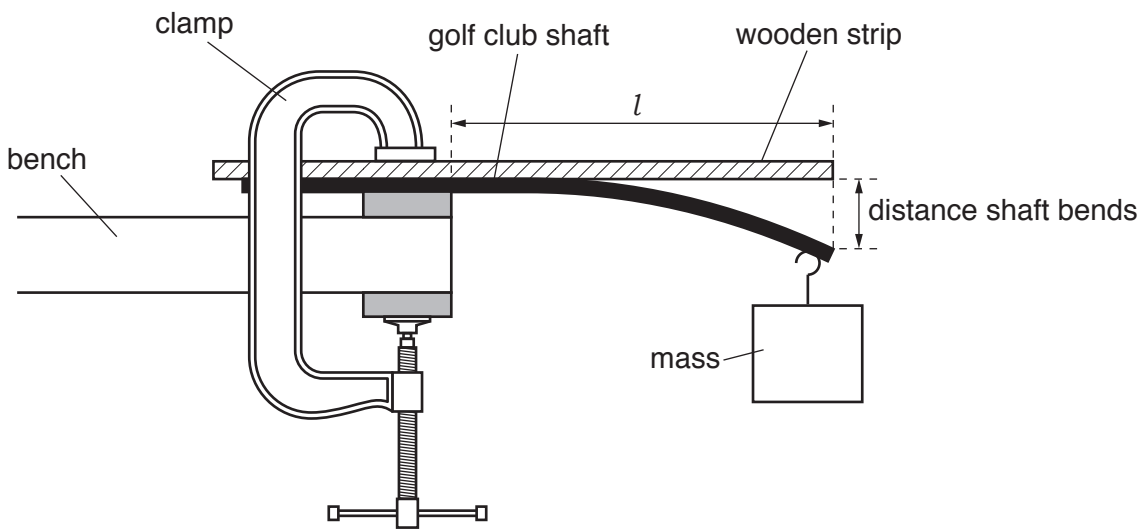

He measures the distance that the shaft bends when the mass is added.

Chris tests several different shafts.

(a) In each test, Chris controls the length of the shaft.
Explain how and why he does this.

.....

.....

.....

.....

[2]

Turn over

(b) Chris tests the flexibility of a golf club shaft.

He repeats his measurements five times for the same shaft.

(i) How can Chris judge whether his measurements are repeatable?

.....
 [1]

These are his results.

| Distance shaft bends in mm | | | | |
|----------------------------|--------|--------|--------|--------|
| Test 1 | Test 2 | Test 3 | Test 4 | Test 5 |
| 86 | 89 | 87 | 88 | 87 |

(ii) Calculate the mean value for the distance the shaft bends.

mean = mm [2]

(iii) The Flex Rating for the shaft is given by the following formula.

$$\text{Flex Rating} = \frac{10000}{3 \times \text{distance shaft bends in mm}}$$

The company wants a shaft which has a Flex Rating of between 38 and 39.

Use the formula to explain if this shaft is suitable.

.....

 [3]

[Total: 8]

7 There are large underground salt deposits between layers of rocks in the north west of England.

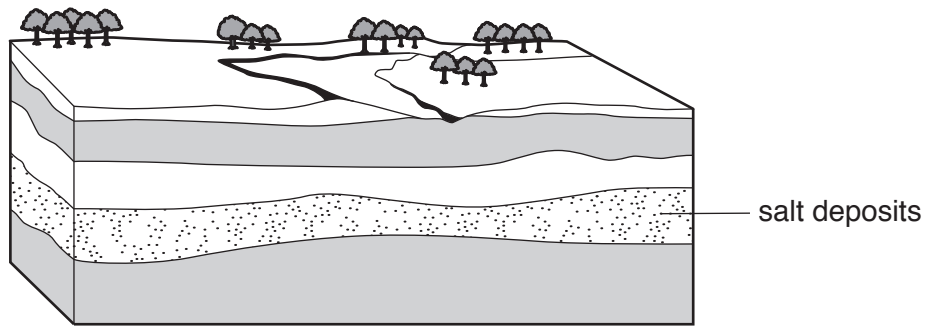

(a) Geologists have looked at the rocks in some of the layers. They found evidence that the rocks were formed under the sea.

(i) Which **two** pieces of evidence show that the rocks were formed under the sea?

Put a tick (✓) in the boxes next to the correct answers.

- The rock is black.
- The rock has ripples on its surface.
- The rock contains fossils of trees.
- The rock contains pieces of shell.
- The rock is hard.

[2]

(ii) The rocks were formed in a hot climate.

Explain how rocks formed in a hot climate are found in the north west of England which has a much cooler climate.

.....

..... [1]

- (b) A company wants to extract the salt from underground and use it for making chemicals. Salt used for making chemicals needs to have a high purity.

The salt deposits are 200 m underground.
Salt can be extracted by two methods.

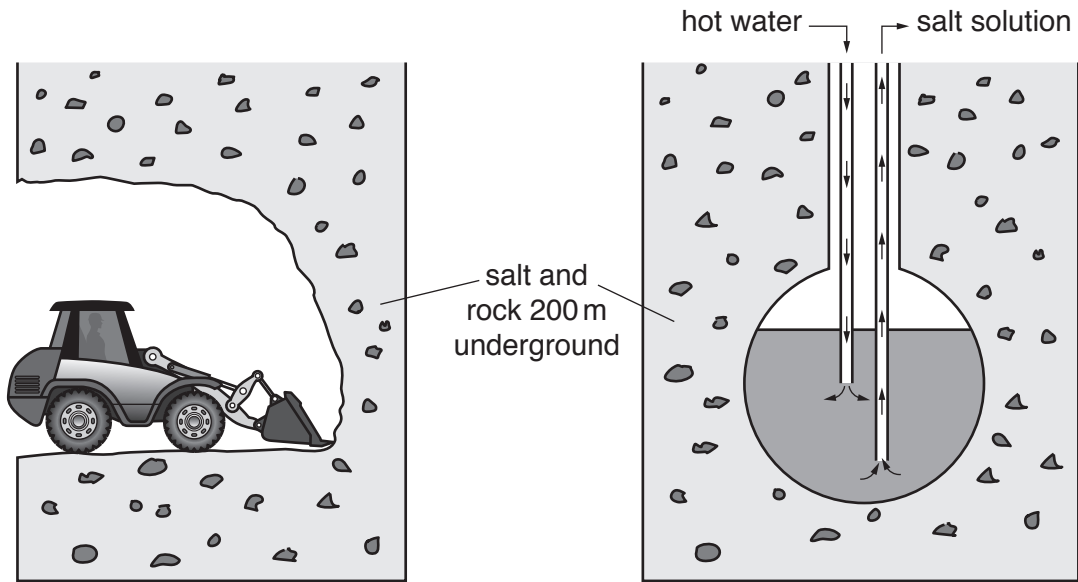

Method 1

Salt mixed with rocks is dug out from underground and brought up to the surface.

Method 2

Water is heated and pumped into the salt and rock. Salt dissolves and salt solution is pumped back to the surface.

8 Before the 19th century, people made alkalis from natural raw materials.

(a) These statements are about making and using alkalis before the 19th century.

Which statements are **true** and which are **false**?

Put a tick (✓) in one box in each row.

| Statement | True | False |
|--|------|-------|
| Alkalis were made from burnt wood and urine. | | |
| Alkalis were made from acids. | | |
| Alkalis were used to make soaps and dyes. | | |
| Alkalis were used as food flavourings. | | |

[2]

(b) In the 19th century a large scale method for making alkalis was developed. The new method produced large amounts of a toxic gas.

In 1874, Henry Deacon invented a new reaction which used up the toxic gas.

This is the equation for the reaction.



Henry Deacon had this to say about his new reaction.



Is what Deacon says correct?

Use the equation to explain your answer.

.....

.....

.....

..... [3]

9 PVC is a polymer used to make clothing.



(a) PVC contains carbon and hydrogen.

Place a **ring** around the other element present in PVC.

oxygen nitrogen chlorine copper phosphorus [1]

(b) Plasticisers are added to the PVC polymer to make it more suitable for clothing.

How does adding a plasticiser change the properties of a polymer?

Put a tick (✓) in the box next to the correct answer.

- The plasticiser makes the polymer stronger.
- The plasticiser makes the polymer stiffer.
- The plasticiser makes the polymer more flexible.
- The plasticiser removes the colour from the polymer.

[1]

(c) Over time, plasticisers leach out slowly from the polymer.

Explain why this causes problems if a polymer with plasticisers is used for making water bottles.

.....

.....

..... [2]

[Total: 4]

END OF QUESTION PAPER

